

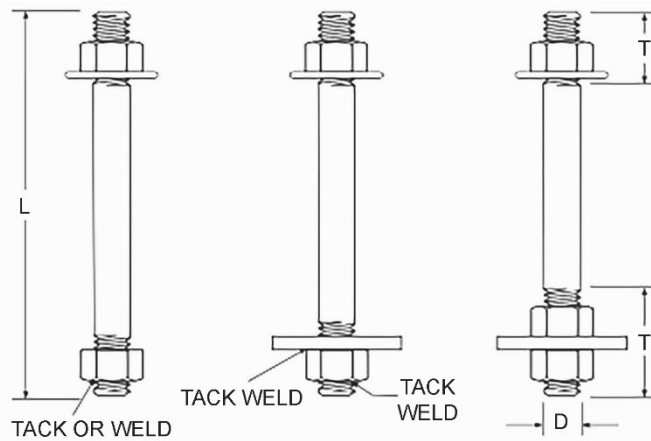

ANCHOR ROD PRODUCT DIMENSIONS

Please make sure to enter all the requested dimensions for **all (4) Areas below**.

Product will be quoted and ordered based on the dimensions listed, all loose hardware is quoted separately.



DIMENSIONS

L: _____

D: _____

T1: _____

T2: _____

TACK WELD?

- STANDARD HEX NUT (QTY: ____)
- HEAVY HEX NUT (QTY: ____)
- ROUND FLAT WASHER (QTY: ____)
- SQUARE PLATE WASHER, SIZE:
(THICKNESS: ____, SQUARE: ____)
- NO TACK WELD NEEDED

FINISH

- PLAIN
- ZINC PLATED
- HOT DIPPED GALVANIZED
- STAINLESS STEEL

GRADE

- 'A' / F1554-36 / A36 / A307 (Low Carbon)
- A449 / F-1554-55 (COMPARE TO GRADE 5)
- A193 B7 / F-1554-105 (COMPARE TO GRADE 8)
- STAINLESS STEEL 304 / A193 B8
- STAINLESS STEEL 316 / A193 B8M
- OTHER: _____

I understand that the Anchor Rods will be produced in accordance with the dimensions listed above and that all special made and/or fabricated items are non-returnable and will have an industry standard +/- 10% for manufactured quantity.

Client Signature: _____ Date: _____